

**Goulais Well 1 and 2 Assessment and Repair Report  
(February 2012)**



INTERNATIONAL WATER SUPPLY LTD

Groundwater Development – Drilling Services  
Pumps – Water Treatment – Service & Maintenance

342 Bayview Drive, P. O. Box 310  
Barrie, Ontario, Canada L4M 4T5  
Tel: 705-733-0111 \*800-461-9636 \* Fax: 705-721-0138  
Email: [iws@iws.ca](mailto:iws@iws.ca) [www.iws](http://www.iws)

February 28, 2012

Sault Ste. Marie PUC Services Inc.  
40 Kresin Engineering Corporation  
536 Fourth Line East  
Sault Ste. Marie, ON  
P6A 5K8

ATTENTION: Orlan Euale, P.Eng.

Reference: Sault Ste. Marie Well Assessment and Repair  
Goulais Well No. 1 and No. 2

As authorized we have completed initial inspection and assessment of the well and pumping equipment of the Goulais Wells No. 1 and No. 2 site. The following is a report of our findings and recommendations.

### Background

Goulais Wells No. 1 and 2 were reportedly constructed by others in or around 1952. Flowing artesian conditions are present at the site. At both wells, a 16 inch casing was installed through the overburden soils to sandstone bedrock at a depth of approximately 160 ft bgl. Open hole in sandstone and shale was then drilled to approx 180'. The cable tool method of drilling is presumed to have been used.

In 1966 IWS Ltd. was contracted to clean out the soft bedrock portion of the well and install 20 ft of 10 inch diameter stainless steel shutter screen and gravel pack the annular space. IWS Ltd. Well drawings are attached. The wells were subsequently developed and each was step tested at rates of 300, 450, 600 and 750 IGM.

In 1967 the wells were equipped with the existing Layne water lubricated style vertical turbine pumps. Well No. 1 was equipped for 1080 USGM at 320 ft TDH. Well No. 2 was equipped for 660 USGM at 320 ft TDH. The pumps have been serviced in 1978 and 1992. No testing or servicing has been reportedly completed since 1992.

### Goulais Well No 1.

A performance test was conducted on 29 Nov 2011. The well was pumped at 3 rates; 3250, 4908, 6200 m<sup>3</sup>/day (600, 900, 1140 USGM) measured by the pump house flow meter. Pumping levels and above head were also recorded.

Pump performance was observed to be significantly low compared to the factory pump curve attached. It was low by 50 ft (approx 20 psi) @ 1140 USGM. This is likely due to wear and internal friction caused by plugging of water passages.

Due to the flowing artesian conditions, well performance is difficult to accurately determine. However the observed pumping levels appear to be less than that observed in 1966. At 750 IGM (900 USGM) the current pumping level was observed to be approx 16 ft bgl compared to 31 ft in 1966. The 1966 test plots are attached for reference.

The Goulais Well No. 1 pump was not removed at this time as it is required to be in operation to reduce the artesian conditions at the site. It is proposed to remove the pump for well and pump inspection and assessment after Goulais Well No. 2 is placed back into operation.

### Goulais Well No. 2.

The Goulais Well No. 2 was not operated to test since a data logger and 10m of cable had been lost down the well and it would likely be damaged or it would damage the pump bowl if it were drawn up into the pump section.

The pump was removed from the well and laid out for inspection. The following was observed:

- The 45 year old pump bowl and column assemblies were found to be in very poor condition.
- The bowl requires a complete rebuild of all bronze bushings and bearings. The impellers are also showing corrosion and thinning of the veins with some fine cracks apparent. They would require replacement.
- The column pipe has a heavy build-up of minerals and beneath the steel pipe is corroded and pitted. The carbon steel line shafts are also heavily coated and corroded. It is not possible to change the stainless steel shaft sleeves or check the shafting for straightness.
- The discharge head appears to be in good condition.
- The PUC Services took the VHS motor to a local service shop for inspection.



A video inspection of Goulais Well No. 2 was conducted on December 6, 2011. A DVD copy of the inspection has been provided for reference. The following observations were made:

- All measurements are recorded in feet with the top of the pump base as the reference measuring point.
- The well was flowing to waste through an overflow fitting near surface during the inspection.
- The 16 inch casing is coated with mineral build-up throughout its length to a depth of 158 ft. No welded joints were visible. The casing had some loose scale in the upper 5 feet. A hard mineral build-up/encrustation begins at approximately 20 ft and becomes slightly heavier with depth. There are no structural concerns with the well apparent.
- At 137 ft the top of the 10 inch screen back off coupling is observed. The 20 ft leader pipe has some mineral build-up as well.
- The data logger and cable were observed at 149 ft. The unit was successfully retrieved.
- The top of the screen was observed at 158 ft. The upper 5 ft section of screen has some minor mineral deposits. The middle sections of screen appeared in excellent condition. The bottom section of screen had some minor mineral deposits and visibility was reduced due to some turbidity, indicating very little flow contribution from this part of the screen.
- The screen bottom plate was not visible since it was covered with approximately 3 ft of accumulated soft mineral debris.

## Discussion and Recommendations

### Goulais Well No. 1

1. Current Well performance at Goulais No. 1 is good compared to historic data. No well maintenance rehabilitation is required at this time. A performance test should be conducted in the Well every 5 years.
2. Pump performance is significantly low compared to the factory performance curve. Considering the 45 year old age of the components and the found condition of the Goulais No. 2 pump, it is likely that new components below the head are required to maintain the safe, efficient and reliable production of the



- Well. A new bowl assembly and a complete water lubricated column assembly with stainless steel shafts will be required.
3. When Goulais No. 2 is returned to service, Goulais No. 1 can be removed for inspection and the likely replacement of the components described above. A well video inspection will be conducted at that time.

#### Goulais Well No. 2

1. The pump was not operated prior to removal so Well performance could not be determined. Since equipped in 1967 with a lower rated capacity pump of 660 USGM, Goulais No. 2 Well performance has not been as good as that compared to Goulais Well No. 1 equipped for 1080 USGM.

At this time it cannot be confirmed if any well maintenance is required. The well video inspection does not suggest that significant deterioration of Well performance would be likely and thus no major well rehabilitation efforts are recommended at this time. The accumulated soft debris at the bottom of the well could be removed at this service interval.

2. A performance test should be conducted when the well is re-equipped with new components.
3. The 45 year old pump was found to be in very poor condition. It is not practical to service the components. The bowl and column assembly below the head should be replaced with new water lubricated style components. Stainless steel shafting should be supplied.

Should you have any questions, please do not hesitate to contact us.

Regards,



John A. Harris, P.Eng

JAH/ww



INTERNATIONAL WATER SUPPLY LTD

Well Material

Outer Casing 16" pipe by others

Inner Casing 21' of 10" Plain End Casing  
Screen 20' of Layne S.S. #1 Opening, 10"

Plug S. S. Plate

Gravel 1-1/2 Yards

Pump

No. 56401 Setting BP-MB 130'  
No. Stages 5 Length Bowl 5'11"  
Bowl 12" RKAH Size & Lgth. Suction 5' x 8"  
Head 8 SDH Size Column 8" x 1-1/2"

Materials or setting details other than standard:  
Impellers: Trim

Motor

Make CGE Phase 3  
H. P. 125 Cycles 60  
R. P. M. 1800 Volts 575  
Type K Amps. 116  
Frame B405TP16 Serial MBJ 1214 167  
Bearing Nos. Upper - 7322.GM/W4  
Lower - 6215-2Z

Special Equipment

Ground Level 0'

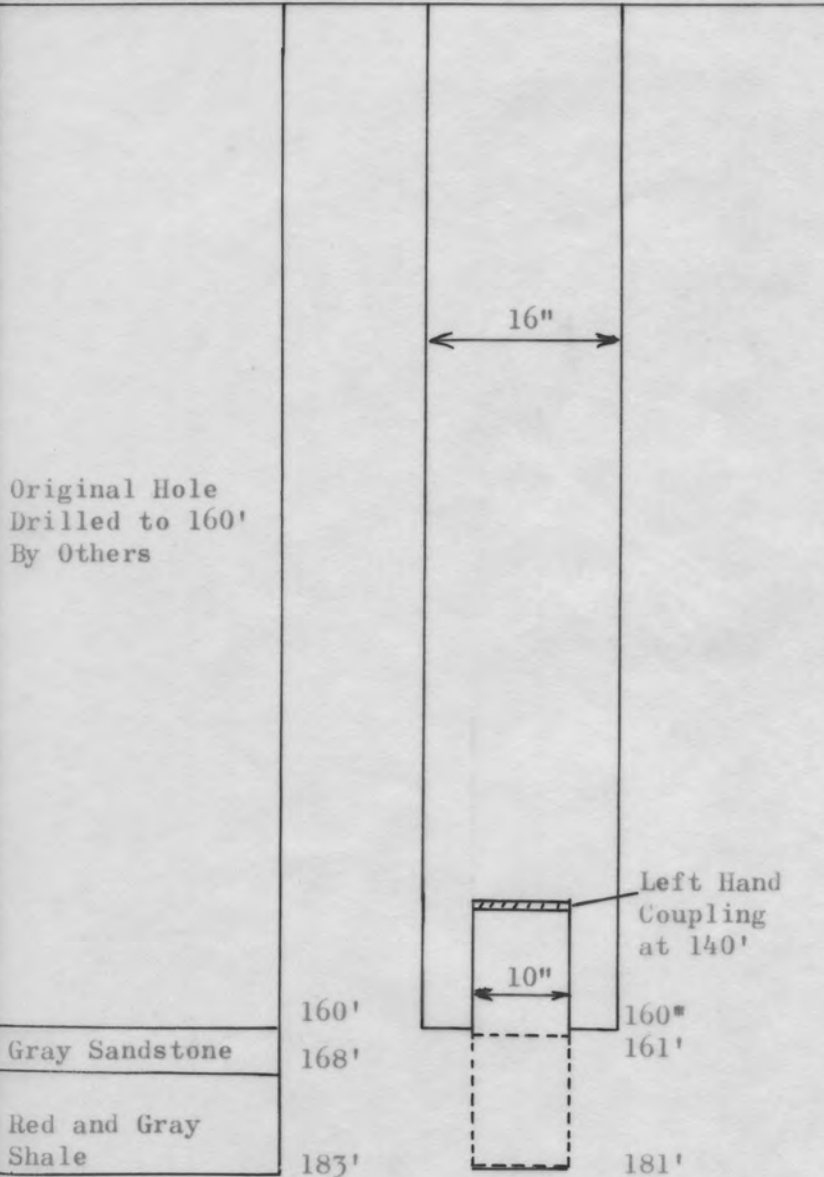

Well No. 1

B.P. referred to original ground level.....  
Clear depth below B.P. ....  
Started Aug. 19, 1966 Final Test Sept. 1967  
Preliminary Test Aug. 29 Static Level +10'  
Final Test Sept. 1967 Pumping Level 11' @ 850 IG  
Guarantee..... 1 G P M Capacity 850 IG P M  
Contract Pressure..... # Pressure Pump 148 #  
Length Air Line 130' Main..... #

MD. 1978 1772 1/2

**INTERNATIONAL WATER SUPPLY LTD.**

MONTREAL LONDON, CANADA SASKATOON  
OAKVILLE WATER SUPPLY CONTRACTORS VANCOUVER

SAULT STE. MARIE, ONTARIO  
GOULAIS AVENUE

DRILLED BY T. Kyle  
INSTALLED BY J. Hartman

DRAWN BY MC  
APPROVED BY *D. Hartman*

Well Material

Outer Casing 16" pipe  
Inner Casing 21' of 10" plain end casing  
Screen 20' of Layne S.S., #1 opening, 10"  
Plug S. S. Plate  
Gravel 1 Yard

Pump

No. 56402 Setting BP-MB 130'  
No. Stages 7 Length Bowl 6'1"  
Bowl 10" RKEHC Size & Lgth. Suction 5' x 6"  
Head 8 SDH Size Column 8" x 1-1/2"

Materials or setting details other than standard:  
Impellers: Trim

Motor

Make CGE Phase 3  
H. P. 75 Cycles 60  
R. P. M. 1800 Volts 550  
Type K Amps.  
Frame B365TP16 Serial 1221553 MBJ  
Bearing Nos. Upper - 7219.GM/4  
Lower - 6212-2Z

Special Equipment

Well No. 2

B. P. referred to original ground level.....  
Clear depth below B. P. ....  
Started Aug. 4, 1966 Final Test Sept. 1967  
Preliminary Test Aug. 15 Static Level +10'  
Final Test Sept. 1967 Pumping Level 32' @ 600 GPM  
Guarantee..... 1 G P M Capacity 550 1 G P M  
Contract Pressure..... # Pressure Pump 130 #  
Length Air Line 130 Main..... #

Ground Level

0'

Original Hole to  
160' Drilled By  
Others

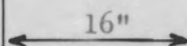

Left Hand  
Coupling  
at 137'

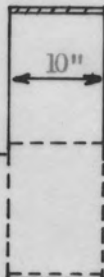

160'

158'  
160'

178'

178'

Red and Gray Shale

**INTERNATIONAL WATER SUPPLY LTD.**

MONTREAL LONDON, CANADA SASKATOON  
OAKVILLE WATER SUPPLY CONTRACTORS VANCOUVER

SAULT STE. MARIE, ONTARIO  
GOULAIS AVENUE

DRILLED BY T. Kyle DRAWN BY mc  
INSTALLED BY J. Hartman APPROVED BY *D. W. Hartman*

No I.R.



CLOCK TIME - HRS.

0800 1000 1200 1400 1600 1800

PUMPING LEVEL - feet

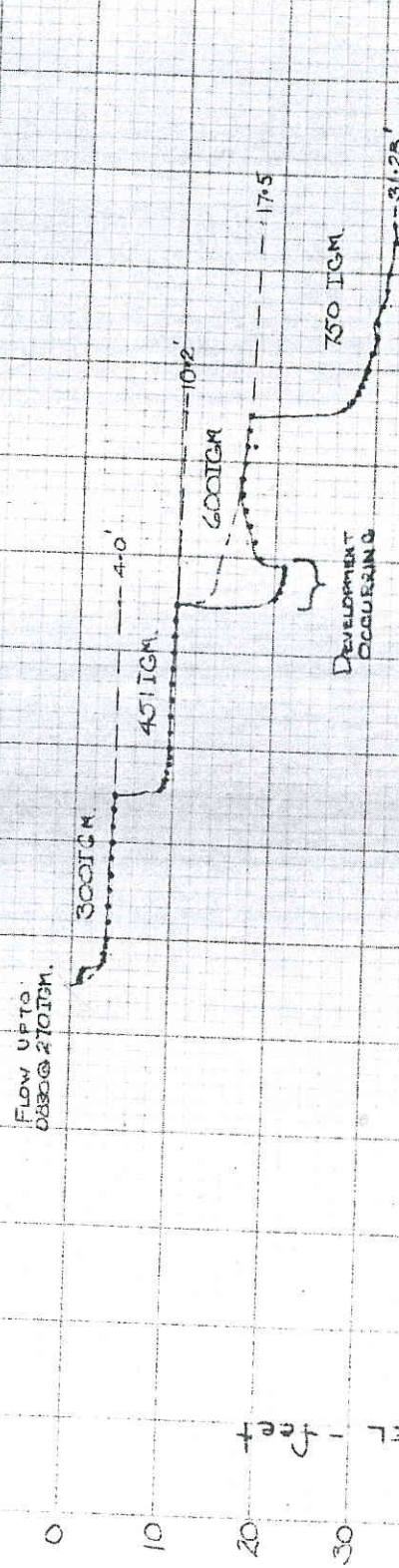

NB. - All levels from flange on 16" casing.

SALT STEAMIE P.O.C.
GOULAIS No. 1.
STEP - TEST.
AUG 29/66

18.





CLOCK TIME - Hrs.

0800 1000 1200 1400 1600 1800

Flow up to  
0900 hrs.

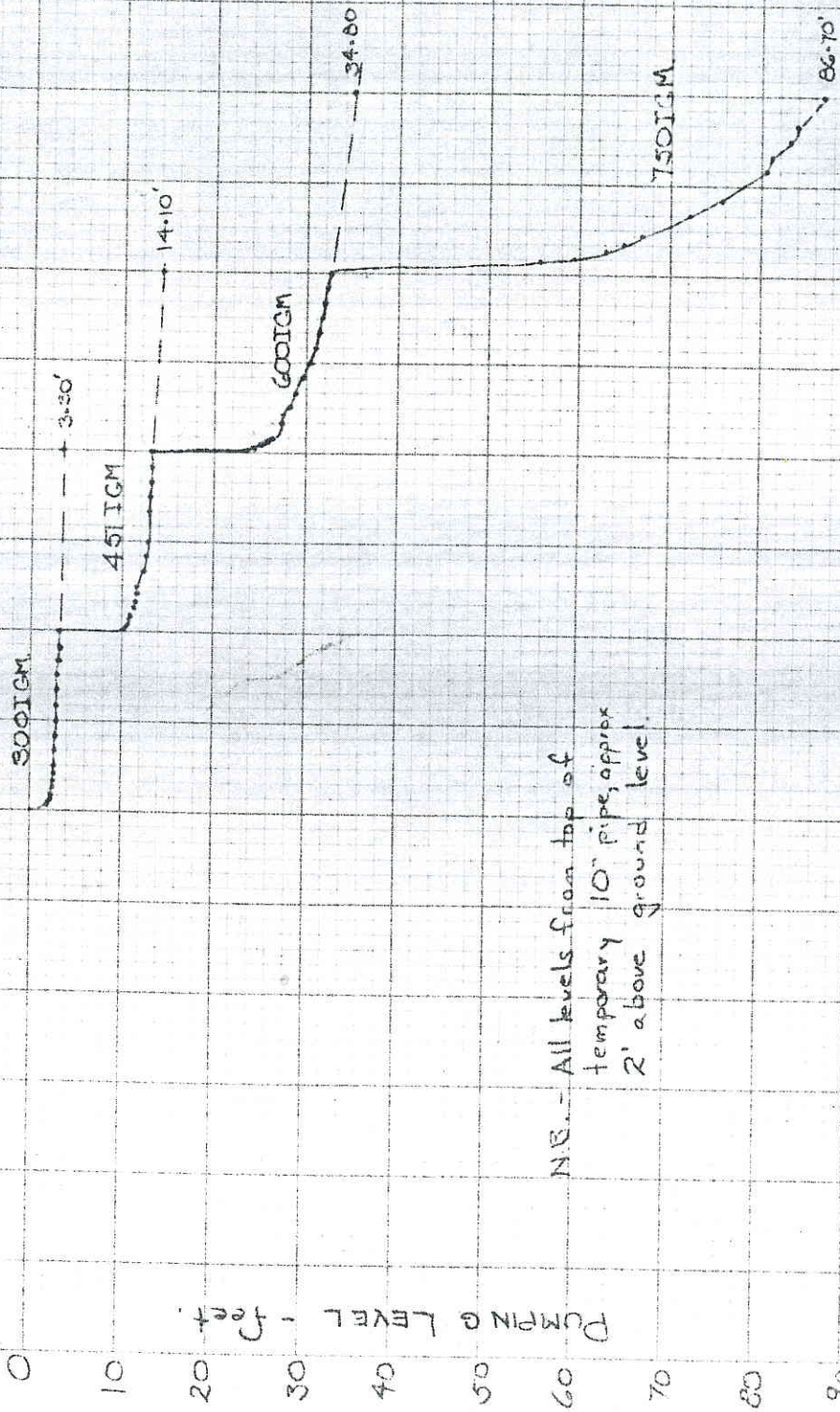

N.B. - All levels from top of  
temporary 10" pipe, approx  
2' above ground level.

SAULT STE MARIE P.U.C.  
GOULAIS No 2.  
STEP-TEST  
AUG 15/66  
18.

LAYNE, R. & POWELL, INC.  
MEMPHIS, TENN.

DEEP WELL TURBINE PUMP PERFORMANCE CHART

CURVE SHEET NO. 15838  
DATE Oct. 4/66

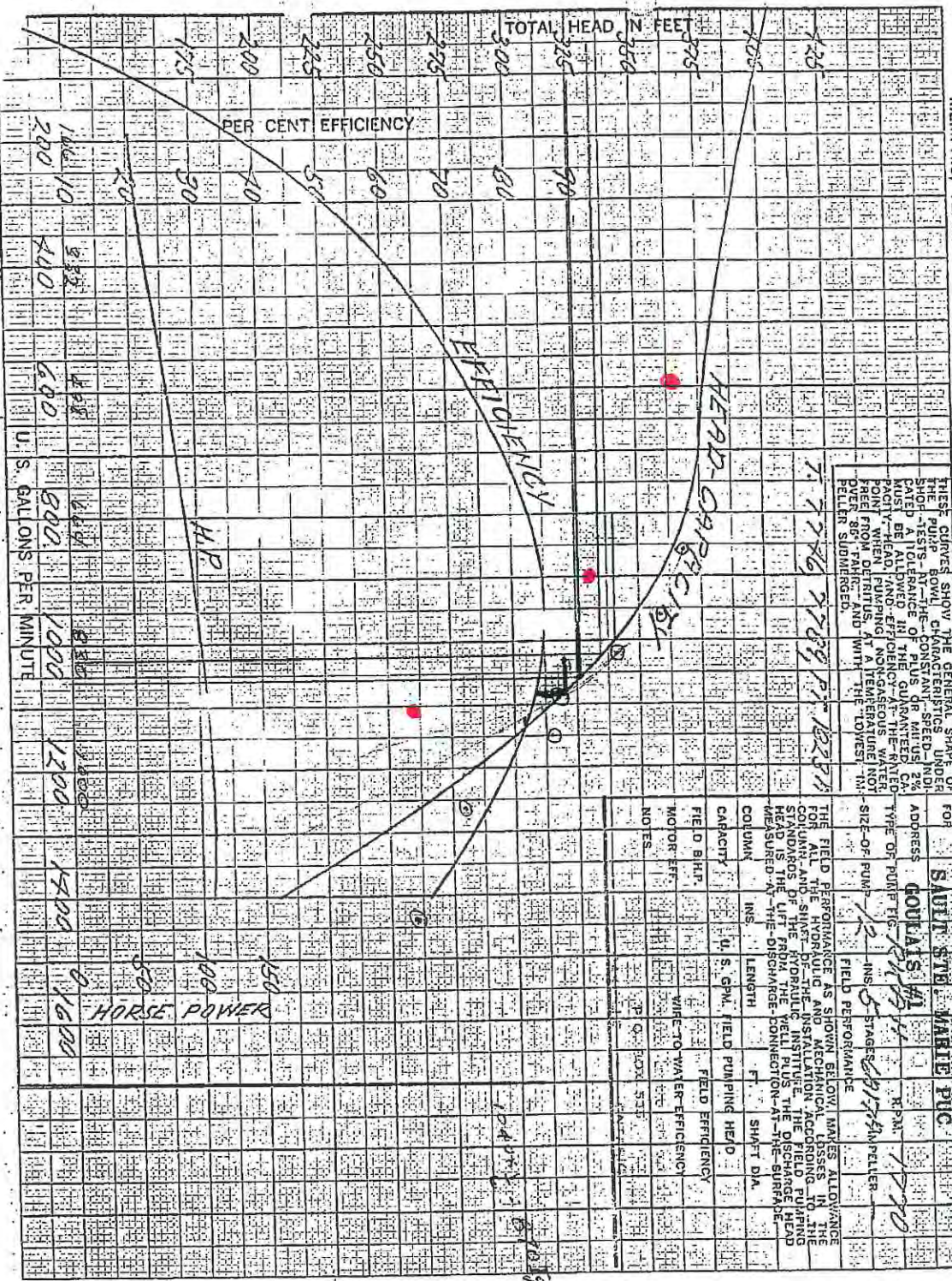

THESE CURVES SHOW THE GENERAL SHAPE OF THE PUMP BOWL. THE CONSTANT SPEED INDICATED IS THE RANGE OF PLUS OR MINUS 2% CAPACITY-HAND AND EFFICIENCY-AROUND THE CENTER POINT WHEN PUMPING AT THE TEMPERATURE NOTED FROM DESIGN AND WITH THE LOWEST BELLS SUBMERGED.

FOR ADDRESS	SUIT NO.	MAILING P.C.	TYPE OF PUMP	INS. STAGES	FIELD PERFORMANCE	FIELD PUMPING HEAD	FIELD EFFICIENCY	WIRE-TO-WATER EFFICIENCY
1776	1776		12	5				

Field Observed  
Nov 29/11

Nov 12  
Lead 46  
122 pwt  
326  
230  
376

**Goulais Well 1 and 2 Assessment and Repair Report  
(June 2012)**



INTERNATIONAL WATER SUPPLY LTD

Groundwater Development – Drilling Services  
Pumps – Water Treatment – Service & Maintenance

342 Bayview Drive, P. O. Box 310  
Barrie, Ontario, Canada L4M 4T5  
Tel: 705-733-0111 \*800-461-9636 \* Fax: 705-721-0138  
Email: [iws@iws.ca](mailto:iws@iws.ca) [www.iws.ca](http://www.iws.ca)

June 22, 2012

Sault Ste. Marie PUC Services Inc.  
C/O Kresin Engineering Corporation  
536 Fourth Line East  
Sault Ste. Marie, ON  
P6A 5K8

Attention: Orlan Euale, P.Eng.

Reference: Sault Ste Marie Well Assessment and Repair  
Goulais Well No. 1 and No. 2

COPY

RECEIVED  
ENTERED  
JUN 27 2012

As authorized we have completed inspection and assessment of the well and pumping equipment of the Goulais Wells No. 1 and No. 2 site. The following is a supplemental report to our initial report of Feb 28, 2012.

Goulais Well No. 1

An investigation into the concern of water seepage through floor tiles was undertaken on April 19, 2012. This consisted of a “shut in test” of Goulais Well 2 well head and plugging of water passages in the Goulais Well 1 pump head. The overflow gate valves to waste were also closed. The shut in test was conducted for 65 minutes and during this time no water was observed to leak around the well casing or up through the floor. The test was witnessed by Kresin Engineering staff.

After reinstalling and operating the new pumping equipment in Goulais Well 2, the pump was removed from Goulais Well 1 on May 7, 2012. The following was observed:

- The 45 year old pump bowl and column assemblies were confirmed to be in very poor condition
- The column pipe had a heavy buildup of minerals and beneath the steel pipe is corroded and pitted. The line shafts were carbon steel and also heavily coated and corroded. It would not be possible to change the stainless steel shaft wear sleeves or to check the shafting for straightness.
- The top shaft was severely worn where it passes through the stuffing box. The stainless wear sleeves and rubber bearings were also worn. At 85 ft and 95 ft setting depth the shaft sleeves were severely worn on one side indicating a vibration or alignment problem. The pump had previously operated with severe vibrations in the discharge piping noted.

- The bowl was determined to be in similar condition to that of Goulais 2 and was not serviceable. It was also noted that the bowl showed signs of slight rubbing on the well casing.
- The discharge head appears to be in good condition.
- The PUC Services took the VHS motor to a local shop for inspection.

The bottom of the well screen was then cleaned out to a firm bottom depth of 183 ft below the base plate. The accumulation of red particles of sandstone and some grey silt were removed.

A video inspection of Goulais Well No. 1 was conducted on May 8, 2012. A DVD copy of the inspection is provided for reference. The following observations were made:

- All measurements are recorded in feet with the top of the pump base as the reference measuring point.
- The well was flowing to waste through an overflow fitting near surface during the inspection.
- The 16 inch casing is coated with a red/brown mineral build-up throughout its length to a depth of 160 ft. Only a few welded joints were visible 1, 8, 65 ft bmp. The hard mineral build up/encrustation and some tubercules are observed and become moderately heavier with depth. It is heaviest at around 130 ft near the pump setting. There are no structural concerns with the well apparent.
- At 139 ft the top of the 10 inch screen back off coupling is observed. The 20 ft leader pipe has some mineral build-up as well.
- The top of the screen was observed at 161 ft. The upper 15 ft section of screen appeared in excellent condition. The bottom section had some minor mineral deposits and visibility was reduced due to turbidity, indicating very little flow contribution from this part of the screen.
- The screen bottom plate at 181 ft in the video is not visible since it was covered with a minor amount of accumulated debris.

The new pumping equipment was installed on May 10, 2012. The replacement bowl assembly is a Layne 12EM-4 stage selected for the same duty as the previous obsolete bowl (1080UGSM@323 ft TDH). It was decided to install the pump for 120 ft of 8 x 1 ½ inch column pipe rather than the 130 ft previously. This was to prevent the pump rubbing on the well casing and causing an alignment/vibration problem. Copies of the pump curve and installation plan have been provided.

Due to the flowing conditions the well could not be disinfected however, the pumping equipment was sprayed with a 200 mg/l solution of sodium hypochlorite. The well was flushed to waste on start up and any residual disinfectant neutralized with sodium thiosulphate dechlor. The pump was found to operate quite well.



### Goulais Well No. 2

The well pump could not be operated prior to removal of the existing pumping equipment on Nov 29, 2011. Following reinstallation of the new pumping equipment and well performance check was conducted.

Due to flowing conditions a true static water level cannot be easily determined. It is assured to be approximately 8 ft agl. At a flow rate of 3300 m<sup>3</sup>/day (500 IGM) water was still observed to flow out the overflow at a rate of approximately 30 IGM. This observed drawdown in the well is less than that reported during testing in 1966 when the pumping level at 451 IGM was approximate 10 ft bgl.

Due to the flowing conditions, the well could no be disinfected however, the pumping equipment was spray disinfected with a 200 mg/l solution of sodium hypochlorite. The well was then flushed to waste on start up and any residual disinfectant neutralized with sodium thiosulphate dechor. The pump was found to operate quite well.

### Conclusions and Recommendations

1. Well performance at both Goulais Well No. 1 and No. 2 is considered good compared to historic test data. A performance test should be conducted on the wells every 4 to 5 years.
2. Regular recording of production, water levels, and above ground head should be maintained in order to monitor any changes in well or pump performance
3. The pumps should be pulled for inspection and servicing of wearing parts in 5 years.
4. When the pumps are removed for servicing a well video inspection should be completed.

If you have further questions, please don't hesitate to contact us.

Regards,



John A. Harris, P.Eng.

JAH/ww



Company: International Water Supply  
 Name:  
 Date: 12/21/2011

SSM Goulais Well 1



**Pump:**

Size: 12EM (4 stage)  
 Type: Vertical Turbine  
 Synch speed: 1800 rpm  
 Curve:  
 Specific Speeds:  
 Dimensions:  
 Vertical Turbine:

Speed: 1770 rpm  
 Dia: 9.125 in  
 Impeller:  
 Ns: —  
 Nss: —  
 Suction: 8 in  
 Discharge: 8 in  
 Bowl size: 12.26 in  
 Max lateral: — in  
 Thrust K factor: 6.33 lb/ft

**Search Criteria:**

Flow: 1080 US gpm Head: 320 ft

**Fluid:**

Water  
 Density: 62.25 lb/ft<sup>3</sup>  
 Viscosity: 1.105 cP  
 NPSHa: — ft

Temperature: 60 °F  
 Vapor pressure: 0.2563 psi a  
 Atm pressure: 14.7 psi a

**Motor:**

Standard: NEMA  
 Enclosure: ODP  
 Sizing criteria: Max Power on Design Curve

Size: 125 hp  
 Speed: 1800  
 Frame: 405T

**Pump Limits:**

Temperature: 150 °F  
 Pressure: 380 psi g  
 Sphere size: 0.94 in

Power: — hp  
 Eye area: 19.4 in<sup>2</sup>

Data Point	
Flow:	1080 US gpm
Head:	323 ft
Eff:	84.4%
Power:	104 hp
NPSHr:	15.7 ft
Design Curve	
Shutoff head:	397 ft
Shutoff dP:	171 psi
Min flow:	— US gpm
BEP:	84.5% @ 1070 US gpm
NOL power:	116 hp @ 1421 US gpm
Max Curve	
Max power:	117 hp @ 1427 US gpm

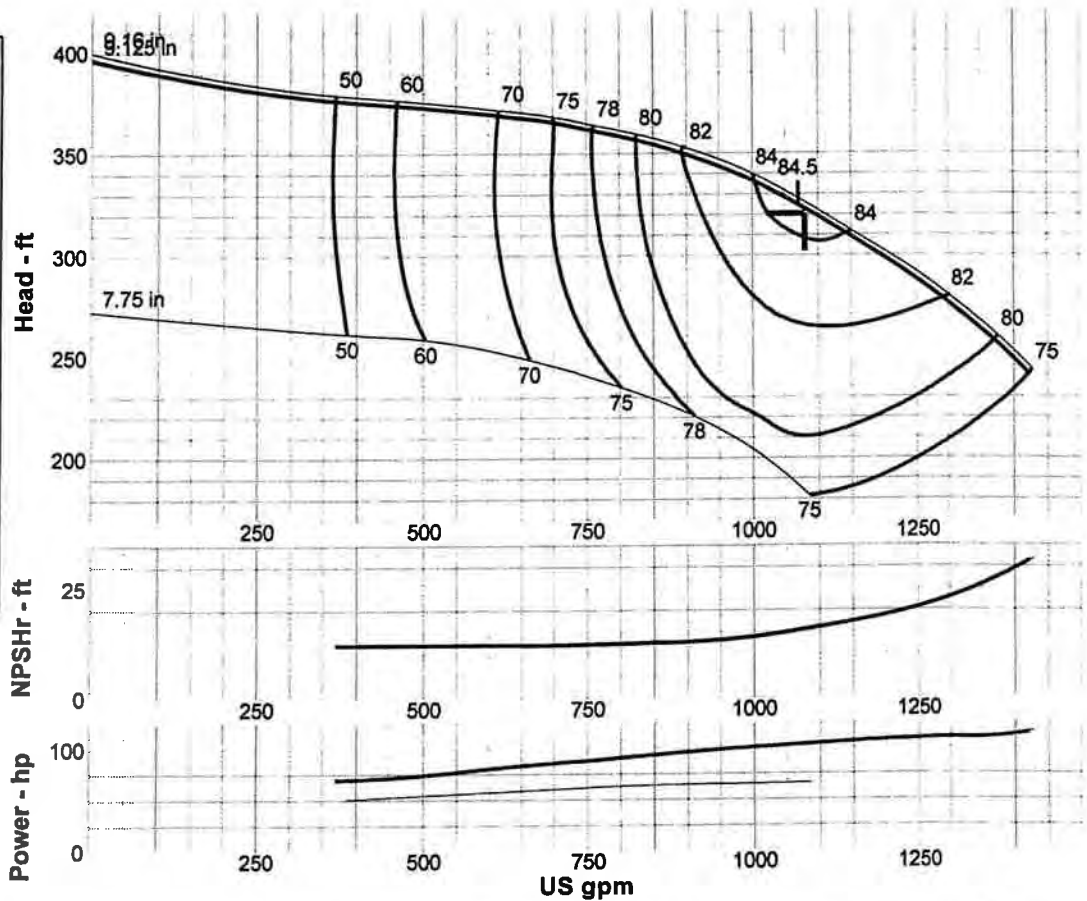

**Performance Evaluation:**

Flow US gpm	Speed rpm	Head ft	Efficiency %	Power hp	NPSHr ft
1296	1770	277	81.9	111	22.8
1080	1770	323	84.4	104	15.7
864	1770	353	81.1	94.9	12.8
648	1770	368	71.9	83.6	12.2
432	1770	375	57	71.7	12.2

# INSTALLATION PLAN TYPE 8 SDH DISCHARGE HEAD

LAYNE & BOWLER, INC. MEMPHIS, TENNESSEE



USE THESE DIMENSIONS ONLY  
WHEN CERTIFIED BY FACTORY

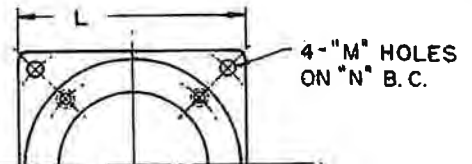
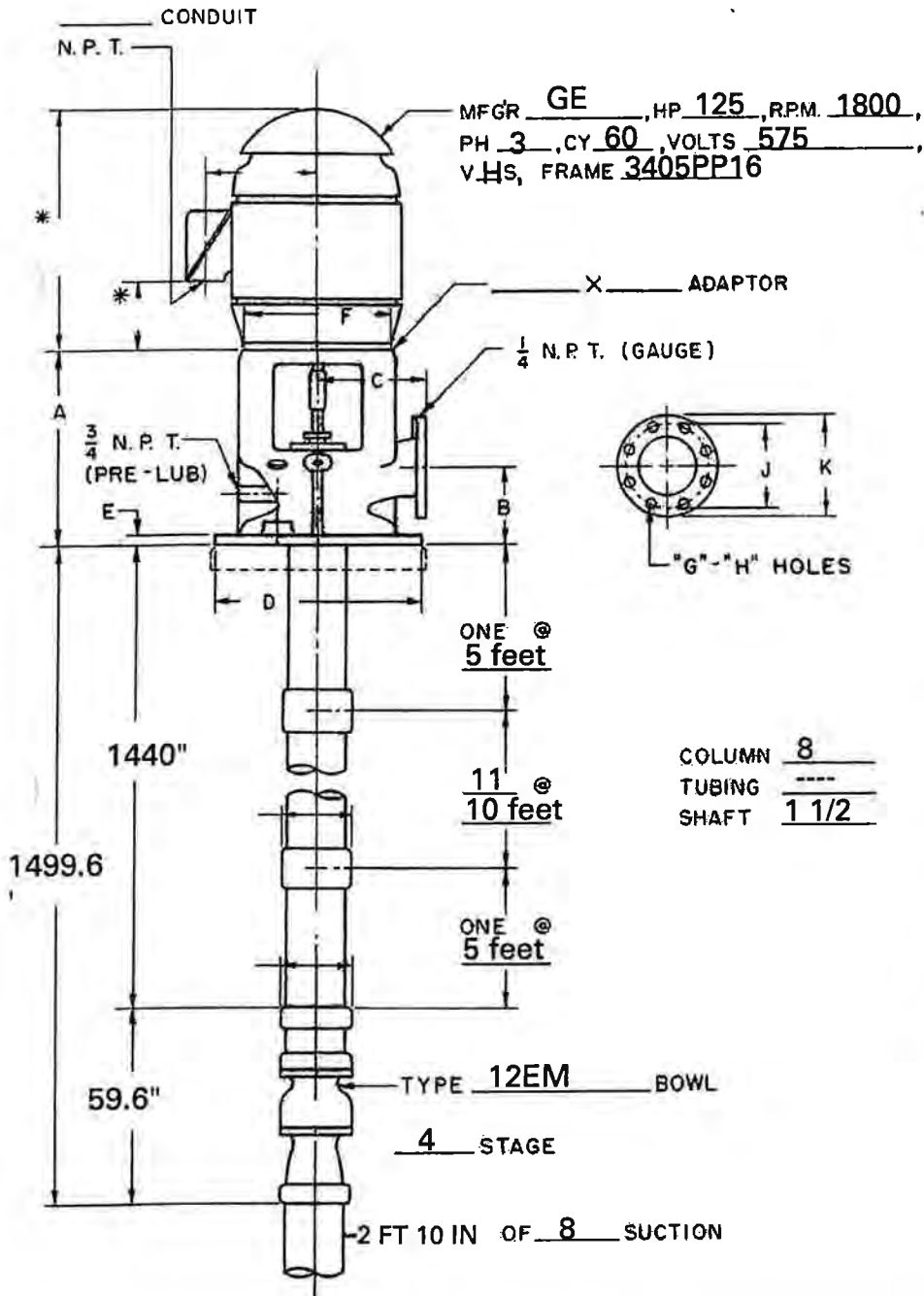

HOLES IN BASE PLATE

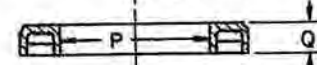

BASE PLATE

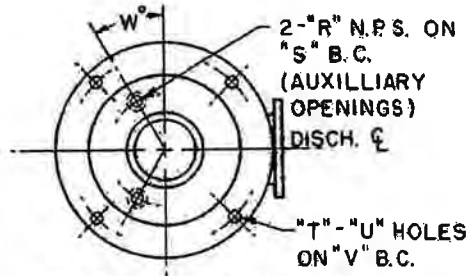

BASE OF HEAD

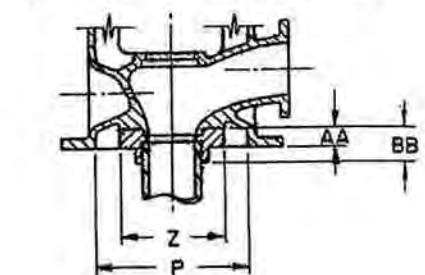
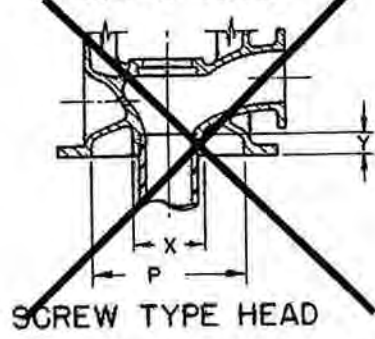

FLANGE TYPE HEAD

CUSTOMER: SAULT STE. MARIE PUC LOCATION: GOULAIS AVE. WELL No. 1 FOR APPROVAL: _____ CERTIFIED: _____	YOUR NO: _____ OUR NO: _____ PUMP NO: 2206686 DATE: MAY 10, 2012	G. P. M: 1080 US T. D. H: 323 FT R. P. M: 1770 B. H. P: 104
--	---	--

TYPE HEAD	HEAD DISCHARGE FLANGE															HEAD BASE												
	125° ASA FLANGE					1250° ASA FLANGE					L	M	N	P	Q	R	S	STD.		125°		V	W	X	Y	Z	AA	BB
	G	H	J	K	G	H	J	K	T	U								T	U									
SDH 3	14	5 1/2	7 1/2	13 1/2	10	4	6	7 1/2	8	6 1/2	8 1/2	13 1/2	15 1/2	9 1/2	1 1/2	7 1/2	4	8	8	12 1/2	11 1/2	24	4 1/2	1 1/2	5 1/2	1 1/2	3 1/2	
SDH 4	16 1/2	6	9	16	12	8	7 1/2	9	8	7 1/2	10	16 1/2	18 1/2	11 1/2	1 1/2	8 1/2	4	12	12	14 1/2	18 1/2	5 1/2	1 1/2	7 1/2	1 1/2	3 1/2		
SDH 6	20	7 1/2	11 1/2	21	16 1/2	8	7 1/2	11 1/2	12	7 1/2	10 1/2	21 1/2	24 1/2	1 1/2	1 1/2	11 1/2	4	12 1/2	12 1/2	19 1/2	20 1/2	7 1/2	1 1/2	10 1/2	1 1/2	4 1/2		
SDH 8	22	8 1/2	13	23 1/2	16 1/2	8	8	11 1/2	13 1/2	12	11 1/2	23 1/2	27 1/2	1 1/2	1 1/2	14	4	16 1/2	16 1/2	21 1/2	20 1/2	10	2 1/2	11 1/2	1 1/2	4 1/2		
SDH 10	25	11	15	27 1/2	20	12	11 1/2	14 1/2	16 1/2	11 1/2	15 1/2	27 1/2	31 1/2	1 1/2	1 1/2	17 1/2	4	20 1/2	20 1/2	25 1/2	24 1/2	12 1/2	2 1/2	14 1/2	1 1/2	5 1/2		
SDH 12	26	11 1/2	17	32 1/2	24 1/2	12	11 1/2	17 1/2	19 1/2	16 1/2	17 1/2	32 1/2	37 1/2	1 1/2	1 1/2	19 1/2	4	20 1/2	20 1/2	29 1/2	17	14	2 1/2	16 1/2	2 1/2	5 1/2		

\* INCLUDES 3" HIGH MOTOR ADAPTOR WHEN USED



Company: International Water Supply  
 Name:  
 Date: 12/21/2011

SSM Goulais 2



**Pump:**

Size: 10RKEH (7 stage)  
 Type: Vertical Turbine  
 Synch speed: 1800 rpm  
 Curve:  
 Specific Speeds:  
 Dimensions:  
 Vertical Turbine:

Speed: 1750 rpm  
 Dia: 7.625 in  
 Impeller:  
 Ns: —  
 Nss: —  
 Suction: 6 in  
 Discharge: — in  
 Bowl size: 9.75 in  
 Max lateral: — in  
 Thrust K factor: 4 lb/ft

**Search Criteria:**

Flow: 660 US gpm      Head: 320 ft

**Fluid:**

Water  
 Density: 62.25 lb/ft<sup>3</sup>  
 Viscosity: 1.105 cP  
 NPSHa: — ft

Temperature: 60 °F  
 Vapor pressure: 0.2563 psi a  
 Atm pressure: 14.7 psi a

**Motor:**

Standard: NEMA  
 Enclosure: ODP  
 Sizing criteria: Max Power on Design Curve

Size: 75 hp  
 Speed: 1800  
 Frame: 365T

**Pump Limits:**

Temperature: 150 °F  
 Pressure: 700 psi g  
 Sphere size: 0.84 in

Power: — hp  
 Eye area: 11.63 in<sup>2</sup>

— Data Point —	
Flow:	660 US gpm
Head:	322 ft
Eff:	80.7%
Power:	66.4 hp
NPSHr:	12.9 ft
— Design Curve —	
Shutoff head:	434 ft
Shutoff dP:	187 psi
Min flow:	— US gpm
BEP:	82% @ 588 US gpm
NOL power:	69.5 hp @ 760 US gpm
— Max Curve —	
Max power:	71.4 hp @ 767 US gpm

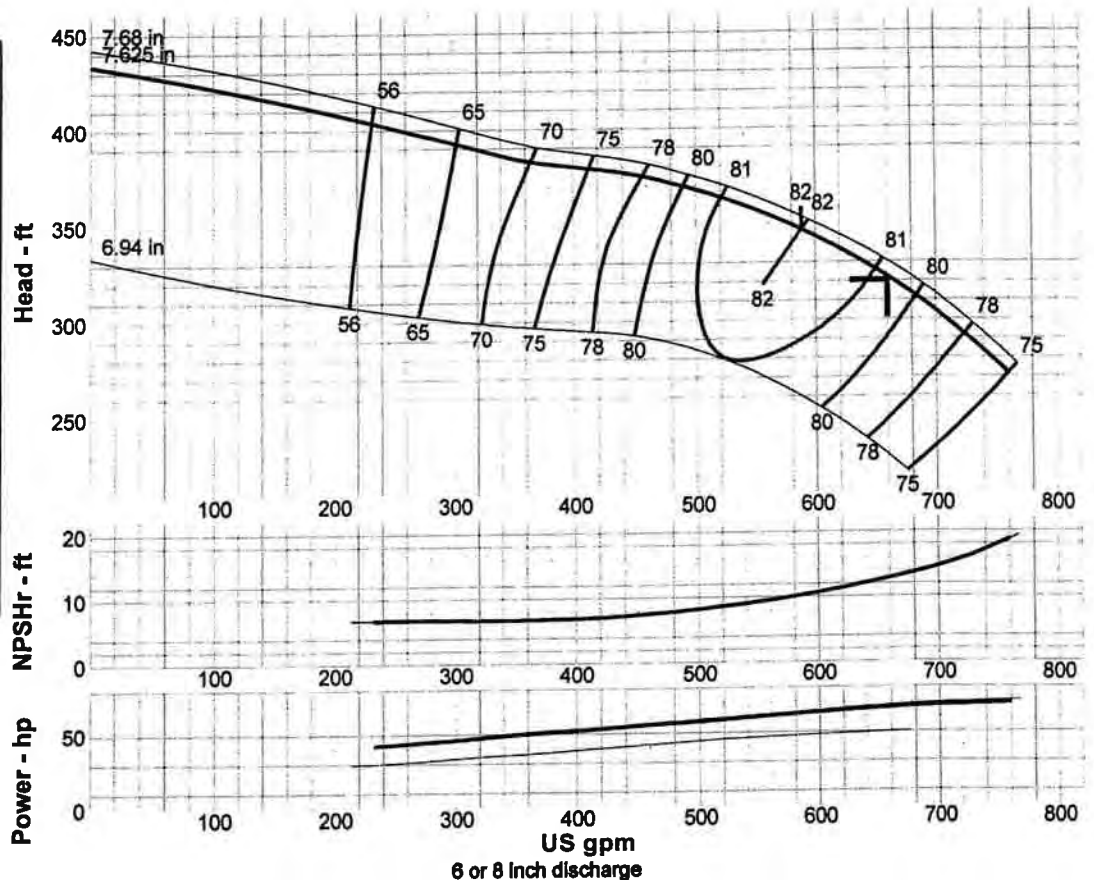

**Performance Evaluation:**

Flow US gpm	Speed rpm	Head ft	Efficiency %	Power hp	NPSHr ft
792	1750	—	—	—	—
660	1750	322	80.7	66.4	12.9
528	1750	362	81.1	59.5	8.86
396	1750	381	73.3	51.9	6.95
264	1750	399	60.1	44	6.81

# INSTALLATION PLAN TYPE 8 SDH DISCHARGE HEAD

LAYNE & BOWLER, INC. MEMPHIS, TENNESSEE



USE THESE DIMENSIONS ONLY  
WHEN CERTIFIED BY FACTORY

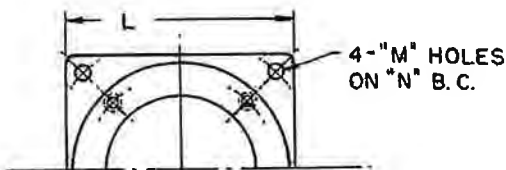
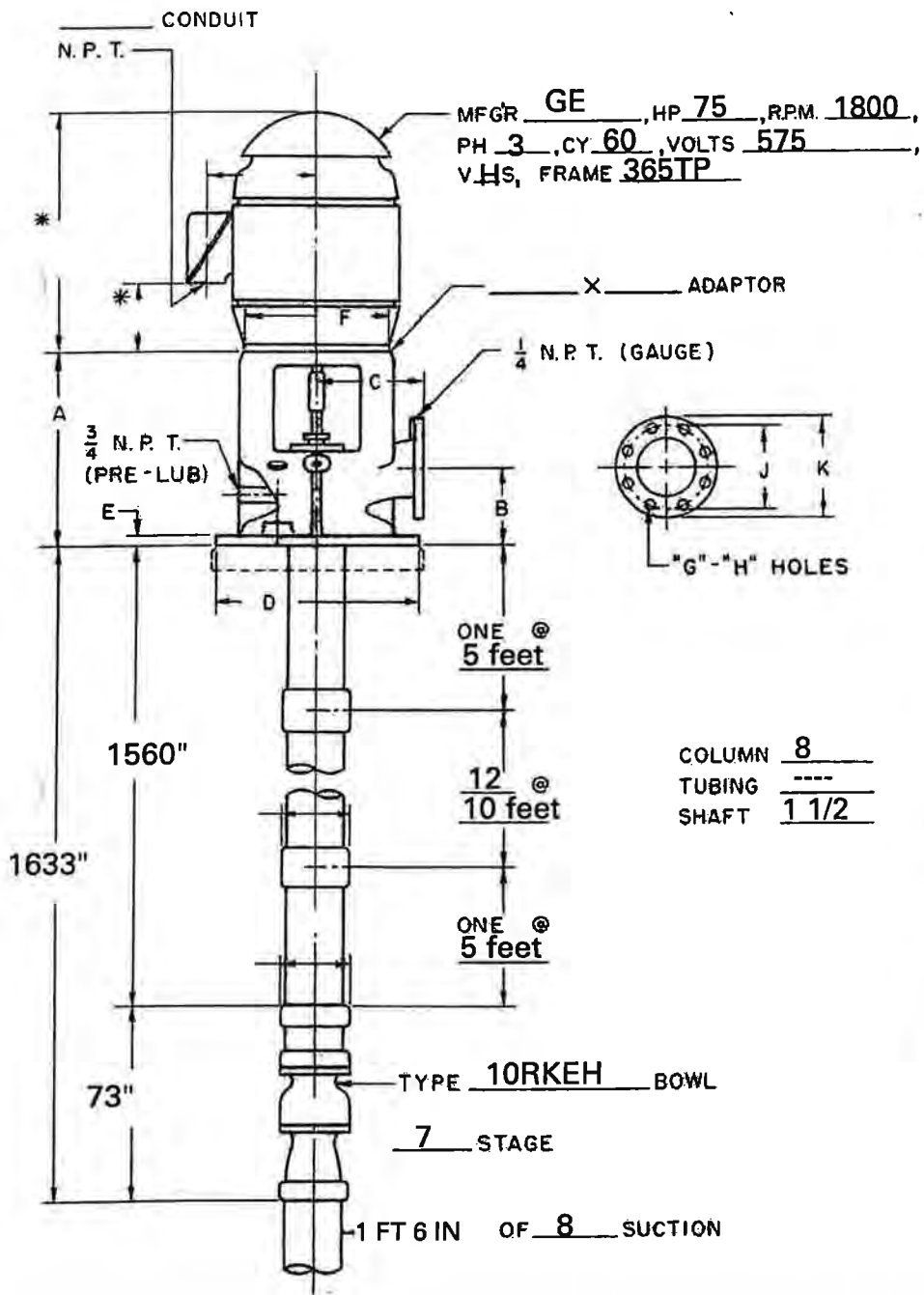

HOLES IN BASE PLATE

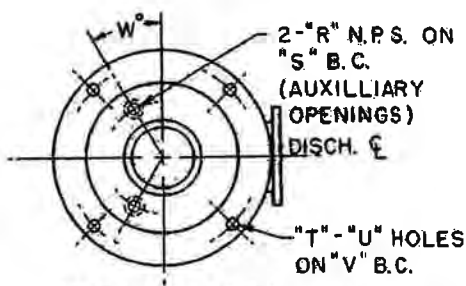
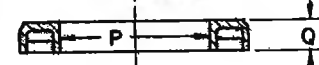

BASE OF HEAD

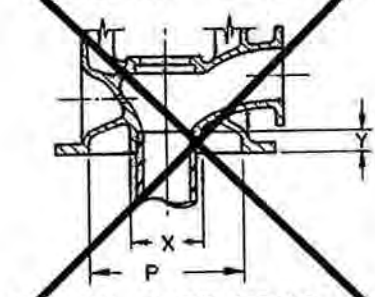

SCREW TYPE HEAD

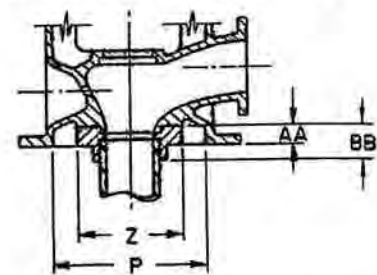

COLUMN 8  
TUBING ----  
SHAFT 1 1/2

CUSTOMER: SAULT STE. MARIE PUC	YOUR NO: _____	G. P. M.: 600 US
LOCATION: GOULAIS AVE. WELL No. 2	OUR NO: _____	T. D. H.: 320 FT
FOR APPROVAL: _____	PUMP NO: 2206718	R. P. M.: 1750
CERTIFIED: _____	DATE: APRIL 28, 2012	B. H. P.: 66.4

TYPE HEAD	HEAD DISCHARGE FLANGE																HEAD BASE											
	125° ASA FLANGE								250° ASA FLANGE								STD.				125°							
	A	B	C	D	E	F	G	H	J	K	L	M	N	P	Q	R	S	T	U	V	W	X	Y	Z	AA	BB		
SDH 3	14	5 1/2	7 1/2	13	10	4	6	7 1/2	8	6	8 1/2	13 1/2	15 3/4	9 1/2	1 1/2	7 3/8	4	8	11 1/2	24	4 1/2	1 1/2	5 1/2	1 1/2	3 1/2			
SDH 4	16 1/2	6	9	16	12	8	7 1/2	9	8	7 1/2	10	16 1/2	18 1/2	11 1/2	1 1/2	8 1/2	4	12	14 1/2	18 1/2	5 1/2	1 1/2	7	1	3 1/2			
SDH 6	20	7	11 1/2	21	16 1/2	10	9 1/2	11	12	10 1/2	12 1/2	21 1/2	24 1/2	1 1/2	1 1/2	11 1/2	4	12	16 1/2	20 1/2	7 1/2	2 1/2	10 1/2	1 1/2	4 1/2			
SDH 8	22	8 1/2	13	23 1/2	16 1/2	8	11 1/2	13 1/2	12	1	13	15	23 1/2	1	27 1/2	16 1/2	2	1	14	4	20 1/2	21 1/2	20	10	2 1/2	1 1/2	4 1/2	
SDH 10	25	11	15	27 1/2	20	12	14 1/2	16 1/2	15 1/2	15 1/2	17 1/2	27 1/2	31 1/2	2	1	17 1/2	4	20	25	24 1/2	12 1/2	14 1/2	14 1/2	1 1/2	5 1/2			
SDH 12	26	11 1/2	17	32 1/2	24 1/2	12	1	17	19	16 1/2	17 1/2	20 1/2	32 1/2	1 1/2	37	24 1/2	2	1	19 1/2	4	20	1 1/2	29 1/2	17	14	2 1/2	1 1/2	5 1/2

\* INCLUDES 3" HIGH MOTOR ADAPTOR WHEN USED